

Information Sheet

Corporation Stop & Nozzle Assembly

New line of Corporation Stop products designed to meet "lead-free" requirements.

The brass components in contact with potable water are designed with a 0.10% maximum lead content which meets certain areas requiring "lead free" or "no lead" fixtures.

No. 49288	1" NPT - Polypropylene Nozzle - Bronze Corporation Stop	170° F (77° C) max.
No. 49289	1" NPT - Carpenter 20 Nozzle - Bronze Corporation Stop	220° F (105° C) max.
No. 49290	1" MUELLER - Polypropylene Nozzle - Bronze Corporation Stop	170° F (77° C) max.
No. 49287	3/4" NPT - CPVC Nozzle - Bronze Corporation Stop	180° F (82° C) max.

- Chemical dispersion away from pipe sidewall to eliminate pipeline corrosion and improve mixing.
- Allows easy nozzle withdrawal for service removal of injection check valve without shutdown of treated line.

INSTALLATION

1. Installation into the line to be treated should be made into the underside of a horizontal pipe. The drill and tap point should be between 4 o'clock and 8 o'clock (the lower 1/3) of the pipe horizontal cross section. (See Fig. 1.) Apply pipe thread sealant to threads and tighten the corporation stop and fitting to 20 foot-pounds.

FOR RETROFIT APPLICATIONS:

Remove and discard the old coupling nut, O-ring, sleeve, washer, chain, clip, screws, and disk. Remove the nozzle, place the appropriate safety cable loop over the corp stop threads, apply Teflon tape and securely screw the retrofit pack joint onto the existing corp stop.

2. Loosen the packjoint locknut and clamp screw. Push the nozzle into the treated line as desired. If the nozzle length "x" as shown in figure 1 is:

–less than 2 1/8"

Do nothing to nozzle and reinsert.

–greater than 2 1/8" but less than 4 1/8"

Cut 2 1/8" from nozzle end and reinsert.

–greater than 4 1/8"

Cut 4 1/8" from nozzle end and reinsert.

Tighten the clamp screw to 30 inch pounds to prevent nozzle slippage, then tighten the packjoint locknut until a hydraulic seal is made.

3. Apply thread sealant tape to injection check valve threads and pass through:

Loop 1 if nozzle length was not changed.

Loop 2 if 2 inches were cut from nozzle end.

Loop 3 if 4 inches were cut from nozzle end.

Screw injection check valve into coupling.

REMOVAL:

1. Loosen clamp screw slowly using proper tool. If the nozzle has not moved out all the way then slowly loosen the packjoint locknut using appropriate tool only. (see figure 2 on next page)
2. Close the corporation stop, remove the safety cable at the injection check valve end and remove the nozzle.

Maximum Operating Pressure 150 PSI

CAUTION:

Nozzle may suddenly jerk out pulling the safety cable tight against the nozzle. Keep hands away by using proper tools to loosen locknut and clamp screw.

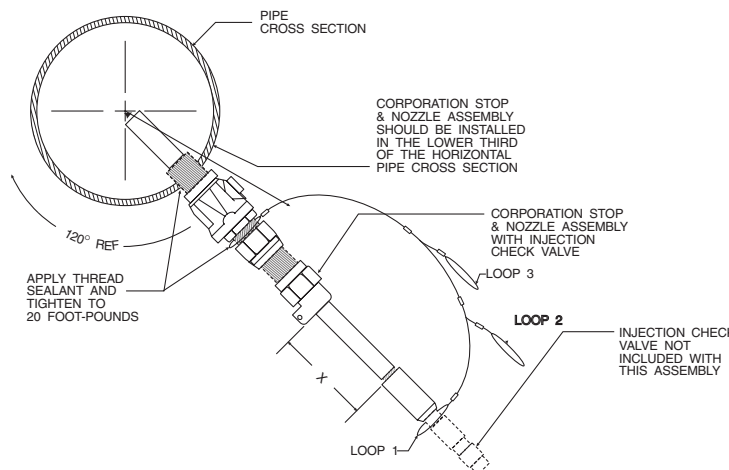

Figure 1
Installation of Corporation Stop



novatech
INTERNATIONAL

sales@novatech-usa.com
www.novatech-usa.com
Tel: (866) 433-6682 Fax: (866) 433-6684
Tel: (281) 359-8538 Fax: (281) 359-0084

201 Ivyland Road
Ivyland, PA 18974 USA
TEL: (215) 293-0401
FAX: (215) 293-0445
<http://www.lmipumps.com>

Figure 2 – Cross Sectional View

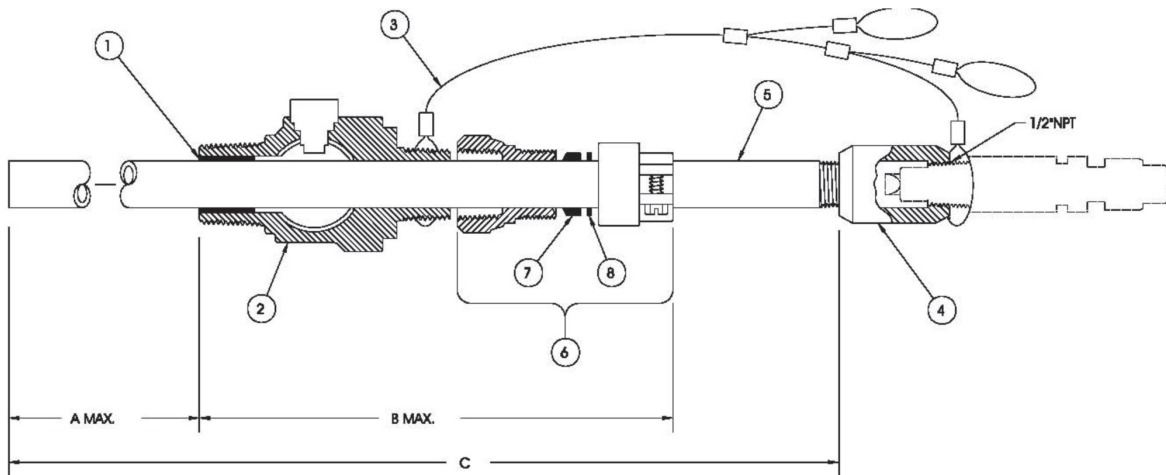

Corporation Stop Interchange:

DIMENSIONS	49287	49288	49289	49290
A MAX. Inches:	7.00	8.00	8.00	8.00
B MAX. Inches:	6.75	7.00	7.00	7.00
C MAX. Inches:	14.00	15.25	15.25	15.25

Legacy Corp Stop P/N	New Corp Stop P/N	Description:
10741	49288	1" NPT – Polypropylene Nozzle – Bronze Corporation Stop: 170°F (77°C) max.
26741	49289	1" NPT – Carpenter 20 Nozzle – Bronze Corporation Stop: 220°F (105°C) max.
27741	49290	1" MUELLER – Polypropylene Nozzle – Bronze Corporation Stop: 170°F (77°C) max.
10998	49287	3/4" NPT – CPVC Nozzle – Bronze Corporation Stop: 180°F (82°C) max.

Key No.	Part Number	Description	Quantity			
			49287	49288	49289	49290
1	25344	Bushing	1			
	26774	Bushing				1
	34091	Bushing		1	1	
2	49282	Corp Stop 3/4" NPT	1			
	49283	Corp Stop 1" NPT		1	1	
	49284	Corp Stop 1" Mueller				1
3*	30896	Safety Cable	1			
	30897	Safety Cable		1	1	1
4	25392	Coupling, CPVC	1			
	10786-1	Coupling, Polypropylene		1		1
	26786-1	Coupling, Carpenter 20 S.S.			1	
5	25336	Nozzle, 3/8 CPVC	1			
	10789	Nozzle, 1/2" Polypropylene		1		1
	26789	Nozzle, 1/2" Carpenter 20 S.S.			1	
6	49295	Packjoint Asm.	1			
	49286	Packjoint Asm.		1	1	1
7	34118	Gasket, Packjoint	1			
	34115	Gasket, Packjoint		1	1	1
8	30970	Ring, Anti-Friction	1			
	34116	Ring, Anti-Friction		1	1	1

* Retrofit Cable Replacement 30898 for Models 49288, 49289, 49290

© 2000 Milton Roy, LLC - All Rights Reserved.
Specifications subject to change without notice.



sales@novatech-usa.com
www.novatech-usa.com
Tel: (866) 433-6682 Fax: (866) 433-6684
Tel: (281) 359-8538 Fax: (281) 359-0084